

Linia de contact

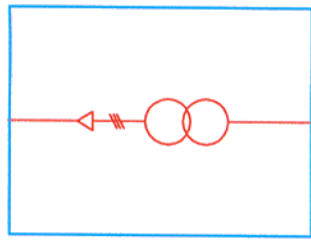

Container fir2

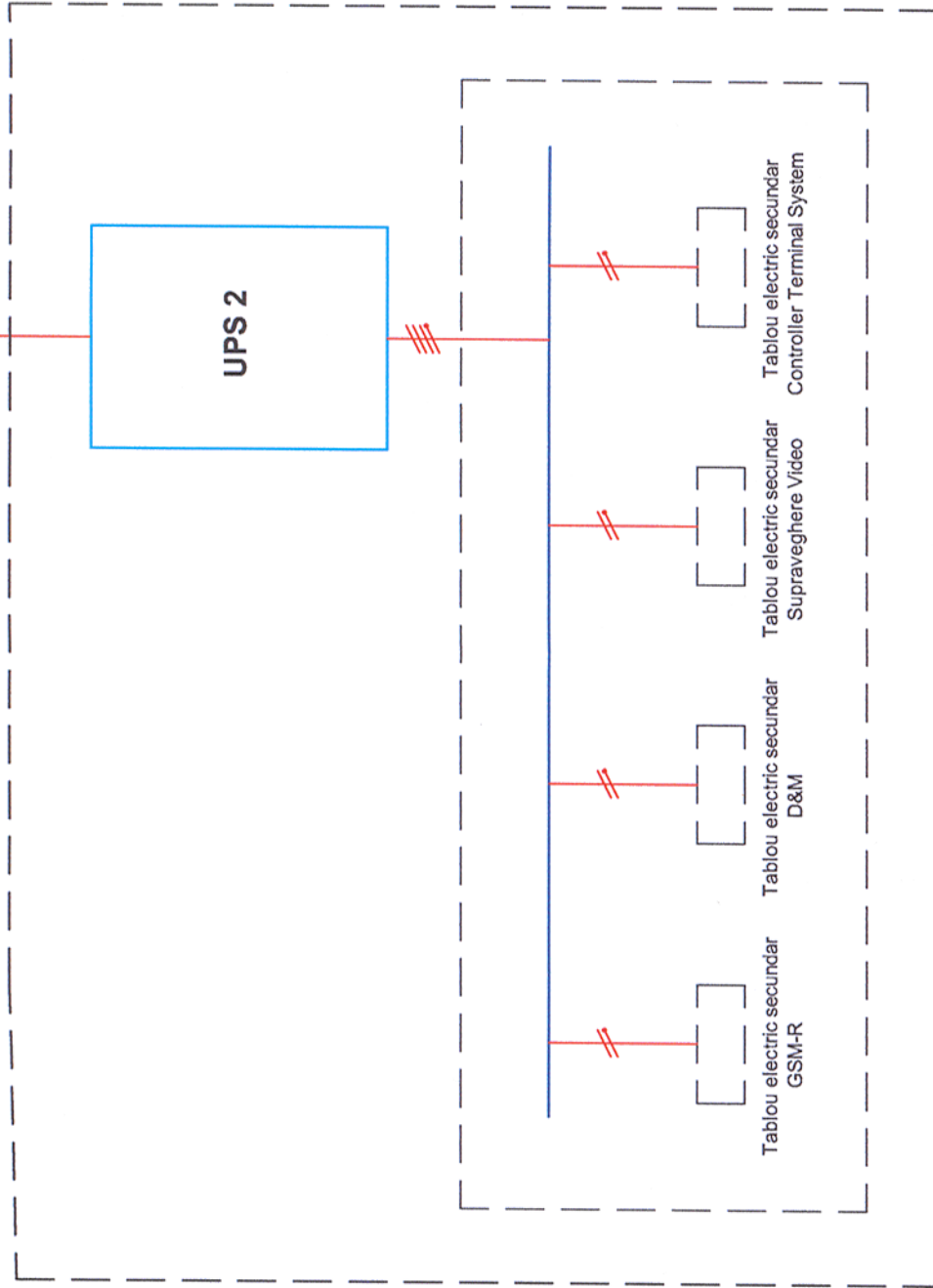

Index / Revision	Data / Date	Descriere / Description	Semnatura / Signature	Semnatura / Signature	Semnatura / Signature
Modificare / Revision	E				
	D				
	C				
	B				
	A				
		PROIECTANT / DESIGNER:		Data / Date	Semnatura / Signature
		Aprobat / Approved Sef de echipa / Team leader	Verificat / Checked Expert Cheie / Key Expert	C. Teodorescu R. Trommer	01.2013 01.2013
		Subcontractant / Subcontractor			
		Aprobat / Approved Adjunct Sef de echipa / Deputy Team leader	Proiectat / Designed Inginer / Engineer	A.M. Baicu A. Sopov	01.2013 01.2013
		"Reabilitarea liniei c.f. Frontiera - Curtici - Simeria, parte componentă a coridorului IV Pan - European pentru circulația trenurilor cu viteză maximă de 160 km/h" "Rehabilitation of the Railway Line Border - Curtici - Simeria, component Part of the IV Pan - European Corridor for the Trains Circulation with maximum speed of 160 km/h" Tronsonul 2-B : cap Y Bârzava - cap Y Ilteu Section 2-B : end Y Bârzava - end Y Ilteu			
		Denumire desen / Drawing Title : Schema electrică generală a containerului GSM-R 559+955 (tunel) / 559+955 (tunel) - General electric sketch GSM-R container			
		Scara / Scale -	Revizia / Revision 1/16.05.2013	Cod desen / Drawing Code PT.02.05.10.SM.127	Nr / No 01/01